

Mechanical Cam Switches
BNS 819-D04-R12-100-10-S4R-I
 Order Code: BNS043H

BALLUFF

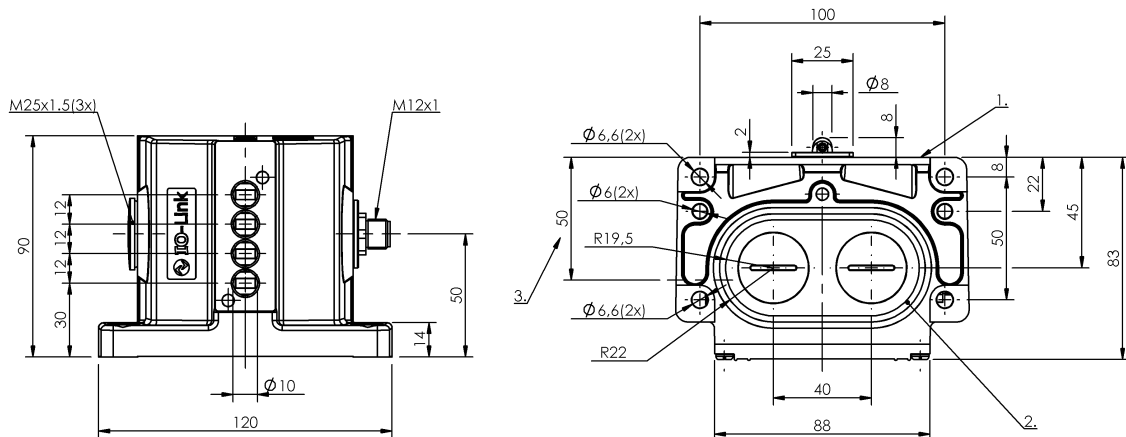

1) Reference edge, 2) Sealing ring, 3) Cable passage



Basic features

Approval/Conformity	CE UKCA WEEE
Basic standard	IEC 60947-5-1
DIN switch	DIN 43697
Operating principle	1-4. Switch position: Mechanical
Version	Snap contact

Display/Operation

Function indicator	1-4. Switch position: None
--------------------	----------------------------

Electrical connection

Connection	M12x1-Flange male, 4-pin, A-coded
Connection type	1. Switch position: Connector

Electrical data

Rated operating voltage Ue DC	24 V
Switching function mechanical	Double-interrupting galvanically isolated One NO and one NC Dual changeover
Switching rate	1-4. Switch position: 300/min

Environmental conditions

Ambient temperature	-5...85 °C
IP rating	IP67

Functional safety

B10d (EN ISO 13849-1)	BSE 30.0: 30 mil. switching cycles
-----------------------	------------------------------------

Interface

Cycle time min.	3 ms
Frame type	2.1
Interface	IO-Link 1.1
Process data cycle min.	3 ms

Material

Housing material	Aluminium, Anodized
Housing material, surface protection	Anodized
Material contacts	1-4. Switch position: Silver, gold plated
Plunger material	1-4. Switch position: 1.4034 stainless steel

Mechanical Cam Switches
BNS 819-D04-R12-100-10-S4R-I
Order Code: BNS043H



Mechanical data

Approach direction	longitudinal, parallel to attachment surface
Approach speed	1-4. Switch position: 60 m/min
Dimension	120 x 90 x 83 mm
Distance cam - reference edge	1-4. Switch position: 4.50...5.00 mm
Flange, feed-through	2 threaded exit M25
Installation	Vertical
Life expectancy mechanical	1-4. Switch position: 30 mil. switching operations

Number of switching positions	4x Roller Mechanical
Plunger spacing 1st switch position	30 mm
Plunger style	1-4th switch position: Roller 1-4th switch position: Roller
Switch actuation force	1-4. Switch position: 20 N
Switching element	1-4. Switch position: BSE 30.0

Range/Distance

Reproducibility	1-4. Switch position: ±0.01 mm
Switch position spacing	12 mm

Connector Drawings

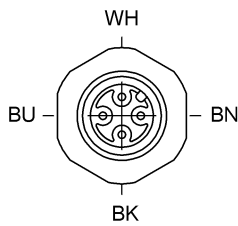

View of connector side

Wiring Diagrams

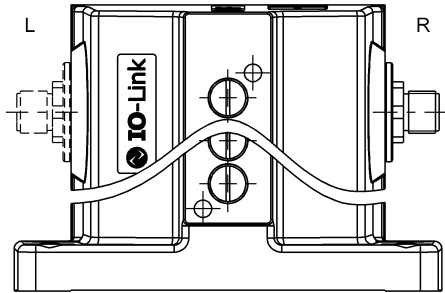

PIN 1: +24V
PIN 3: 0V
PIN 4: IO-Link



Help Views

BNS with IO-Link from 1 up to 16 positions

Frame type: 2.1
 Process data length: 1 Byte

Process data image:

Process data: ≤ 8 positions							
Byte 0							
7	6	5	4	3	2	1	0
NO / NC 8	NO / NC 7	NO / NC 6	NO / NC 5	NO / NC 4	NO / NC 3	NO / NC 2	NO / NC 1

Process data: > 8 positions															
Byte 0								Byte 1							
7	6	5	4	3	2	1	0	7	6	5	4	3	2	1	0
NO / NC 16	NO / NC 15	NO / NC 14	NO / NC 13	NO / NC 12	NO / NC 11	NO / NC 10	NO / NC 9	NO / NC 8	NO / NC 7	NO / NC 6	NO / NC 5	NO / NC 4	NO / NC 3	NO / NC 2	NO / NC 1

On-request data:

	DPP		SPDU		Object name	Length	Range	Default value
	Index	Index	Index	Sub-Index				
Identification Data	0x07				Vendor ID	2 Byte	read only	0x0378
	0x08				Decice ID	3 Byte		0x01010X X = No. of positions
	0x09							BALLUFF
	0x0A				Vendor name	7 Byte		www.balluff.com
	0x0B				Vendor text	15 Byte		BNS 819-xxx-xxx-xx-S4x-I
		0x10	0		Product name	31 Byte		BNSxxxx
		0x11	0		Product ID	7 Byte		BNS xx-fach
		0x12	0		Product text	10 / 11 Byte		
		0x13	0		Hardware Revision	2 Byte		
Programmable Data			0x40	0	NO / NC	≤ 8 positions = 1 Byte	0x00 - (2^positions)-1 (1 Bit = 1 position)	"0"
						> 8 positions = 2 Byte		
			1 - 16			1 Byte		

Errors:

Class			Error Code	Additional Code
Mode	Type	Instance		
single shot	Error	AL	Device application error	Index not available
0x40	0x30	0x03	0x80	0x11
			0x80	0x11
single shot	Error	AL	Device application error	Sub-Index not available
0x40	0x30	0x03	0x80	0x12
			0x80	0x12

Input data: No input data available